



WHY CHOOSE QUALITY STEEL ANHYDROUS AMMONIA (NH3) TANKS?

- 1,000 - 2,000 WG CAPACITY
- General Specifications
 - All tanks are made in America at the Fremont, Ohio, plant and shipped direct from that location
 - Stringently manufactured to the requirements of the ASME code for your safety
 - Engineered roll-over cage with heavier steel and greater accessibility to valves
 - Roll-over cage mounted on welding pads for maximum strength and is field repairable
 - 30% more working clearance from liquid withdrawal valve and safety handle
 - Seal welded stainless steel data plate mounted on pads and away from hose connections for longer life
 - Superior leg design that is stronger, field repairable, mounted on a welding pad
 - Precise fit before weld with 100% x-ray of long-seam welds
 - Advanced powder paint coating to resist exterior corrosion
 - All tanks are fully stress relieved to help alleviate stress corrosion
 - All tanks are vacuum purged
 - Standard tanks are shipped with stainless steel float gauges, water bottle attachments and two drain plugs
 - A three-year limited warranty is in place along with largest, most experienced sales and customer support team
- Financing and leasing available
- Customized delivery programs available

HOW DO I FIND MY SALES REP?

Visit our website, www.propanetank.com to view a list of our reps. Once on our site you'll be able to choose the Commercial options and from there you'll be taken to a list of US states where you can choose your location and view the contact information for your local sales rep. If you don't see your sales rep. please give us a call at 800-345-2495.

Our manufacturing locations are strategically located to help serve your tank needs.

OHIO LOCATION
721 Graham Drive
Fremont, OH 43420
419-334-2664

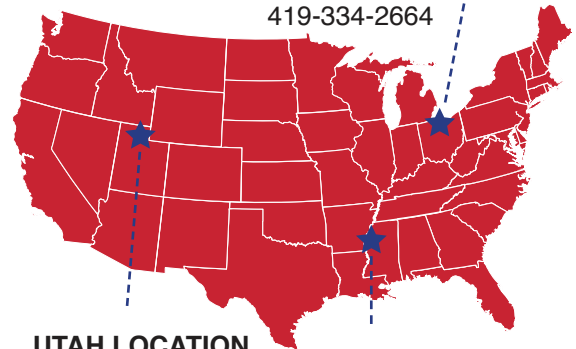

UTAH LOCATION
5601 Axel Park Rd.
West Jordan, UT 84081
801-280-1133

HOME OFFICE
2914 U.S. 61
Cleveland, MS 38732
800-345-2495



We want to make it easier for you to do your tank business!



QUALITY STEEL

Because Quality Steel Means Quality Tanks
★ Thank You for Supporting USA Manufacturers ★

ANHYDROUS AMMONIA (NH3)

Consult our dimension and specification chart below to find the tank that best fits your needs. Visit our website at www.pranetank.com for more information.

Vessels shown with optional safety equipment brackets and end mount float gauge.

Water bottle and safety equipment by customer.

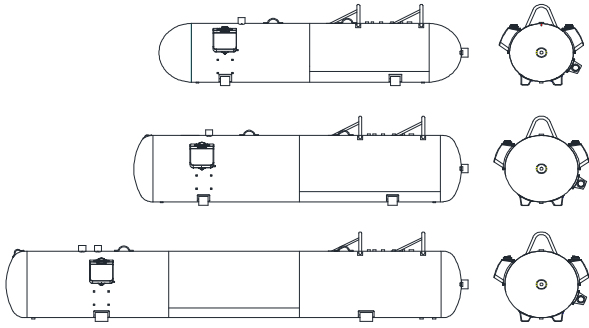

Quality Steel Corporation NH3 Nurse Tanks

Capacity (gallons)	Diameter (OD)	Head Type	Overall Length	Overall Height	Leg Bolt Spacing		Weight (lbs.)
					Length	Width	
1000	41"	Hemi.	16'	4'-9 1/2"	9' o.c. 10' o.c.	21" o.c. 21" o.c.	1,800
1450	46.5"	Ellip.	17'-3 3/4"	5'-4"	10' o.c. 12'-1"	21" o.c. 21" o.c.	2,658
2000	46.5"	Ellip.	24'-1"	5'-4"	14'	21" o.c.	3,765

Dimensions and specifications shown are approximate. Individual vessels may vary

Standard Fitting Arrangement

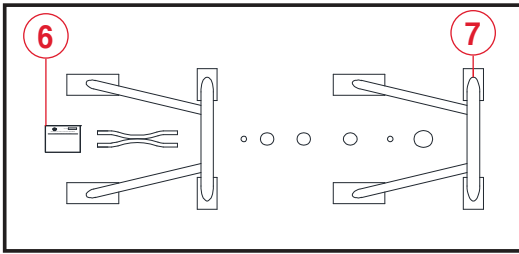

1. 1 1/2" liquid withdrawal
2. Pressure gauge
3. Vapor/Fill
4. Float gauge
5. Fixed outage gauge
6. Tank name plate
7. Roll cage/valve guard



Pressure relief valve(s) not shown



HOME OFFICE
2914 U.S.61
Cleveland, MS 38732
800-345-2495

OHIO LOCATION
721 Graham Drive
Fremont, OH 43420
419-334-2664

UTAH LOCATION
5601 Axel Park Rd.
West Jordan, UT 84081
801-280-1133